

Exploit Your Truck Better with an Integrated Fork Positioner from e-l-m!

An integrated fork positioner from e-l-m produces higher residual capacity on your truck. In many cases, a higher residual capacity can result in the need for a smaller truck.

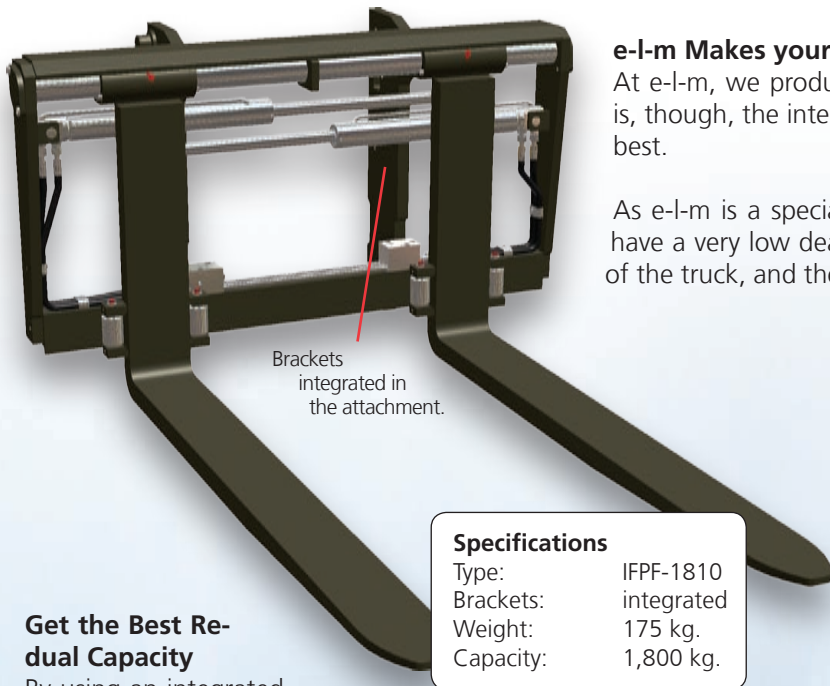

e-l-m Makes your Truck Perform Harder

At e-l-m, we produce both integrated and hook-on fork positioners. It is, though, the integrated solution, which uses your truck's potential the best.

As e-l-m is a specialist in producing integrated solutions, our products have a very low dead weight, which also increases the residual capacity of the truck, and thereby exploiting the truck's possibility to the fullest.

Specifications

Type:	IFPF-1810
Brackets:	integrated
Weight:	175 kg.
Capacity:	1,800 kg.

Get the Best Residual Capacity

By using an integrated fork positioner, you ensure that the lost load centre is as small as possible, and thereby you get a higher residual capacity on your truck.

The smallest possible lost load centre combined with low weight of the attachment results in minimum loss of lifting capacity. A higher residual capacity can in many cases result in that you do not need a bigger truck compared to competing products.

Calculate the residual capacity easily at...

www.e-l-m.com

